

8505**SOUPRAVY ŠROUBOVÁKU MAGNETICKÉHO S NÁSTAVCI**
MAGNETIC SCREWDRIVER KIT WITH BITS**S LINE PROFI**

Code		8505 01	
Velikost Size	Obsah Content	g	
0,8 x 5,0 x 90	8044 02		
1,0 x 6,0 x 90	03		
PH 1 x 90	8045 01		
PH 2 x 90	02	239	
PZ 1 x 90	8046 01		
PZ 2 x 90	02		
šroubovák screwdriver	8320 18		

Code		8505 02	
Velikost Size	Obsah Content	g	
PH 1 x 90	8045 01		
PH 2 x 90	02		
PH 3 x 90	03		
PZ 1 x 90	8046 01	235	
PZ 2 x 90	02		
PZ 3 x 90	03		
šroubovák screwdriver	8320 18		

Code		8505 03	
Velikost Size	Obsah Content	g	
TX 6 x 90	8047 06		
TX 10 x 90	10		
TX 15 x 90	15		
TX 20 x 90	20	227	
TX 25 x 90	25		
TX 30 x 90	30		
šroubovák screwdriver	8320 18		

**8505 01****8558****SADY ŠROUBOVÁKŮ**
SCREWDRIVER SETS**S LINE PROFI**

Code		8558 50	
Velikost Size	Obsah Content	g	
3,0 x 75	8391 01		
4,0 x 100	02		
6,5 x 150	06	413	
PH1 x 80	8393 01		
PH2 x 100	02		

Code		8558 51	
Velikost Size	Obsah Content	g	
3,0 x 75	8391 01		
4,0 x 100	02		
6,5 x 150	06	413	
PZ1 x 80	8394 01		
PZ2 x 100	02		

Code		8558 70	
Velikost Size	Obsah Content	g	
3,0 x 75	8391 01		
5,5 x 125	04		
6,5 x 150	06		
PH1 x 80	8393 01	549	
PH2 x 100	02		
PZ1 x 80	8394 01		
PZ2 x 100	02		

**8558 50****8627****SADY ŠROUBOVÁKŮ v kufru**
SCREWDRIVER SETS in box**S LINE PROFI**

Code		8627 01	
Velikost Size	Obsah Content	g	
3,0 x 75	8391 01		
4,0 x 100	02		
5,5 x 125	04		
6,5 x 150	06	890	
PH1 x 80	8393 01		
PH2 x 100	02		
PH3 x 150	03		

Code		8627 02	
Velikost Size	Obsah Content	g	
3,0 x 75	8391 01		
4,0 x 100	02		
5,5 x 125	04		
6,5 x 150	06	890	
PZ1 x 80	8394 01		
PZ2 x 100	02		
PZ3 x 150	03		

**8627 01**

**8364**
ŠROUBOVÁK UNIVERZÁLNÍ KŘÍŽOVÝ 6 v 1
 UNIVERSAL CROSS SCREWDRIVER 6 in 1

S LINE

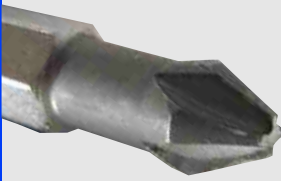

NEW



Code	PH1,PH2,PH3 PZ1,PZ2,PZ3	mm	mm	g	
8364 00		100	100 x 34	105	20

Balení - Blister
Packing - Blisterviz strana 21
see page 21**8002**
ŠROUBOVÁK BEZPEČNOSTNÍ SP
 SAFETY SCREWDRIVER SP

S LINE PROFÍ



NEW

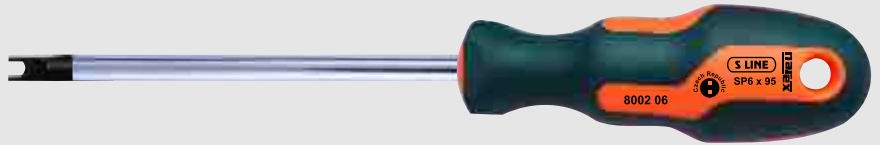

Code	Velikost Size	φd	mm	mm	g	
8002 06	SP 6	6	95	100 x 34	71	20
08	SP 8	6	95	100 x 34	71	20
10	SP 10	6	95	100 x 34	73	20

**8003**
ŠROUBOVÁK BEZPEČNOSTNÍ TW
 SAFETY SCREWDRIVER TW

S LINE PROFÍ



NEW

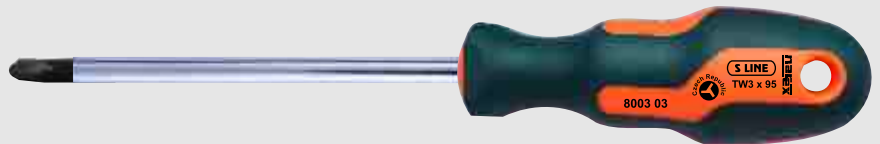

Code	Velikost Size	φd	mm	mm	g	
8003 02	TW 2	4,5	80	90 x 29	44	20
03	TW 3	6	95	100 x 34	72	20
04	TW 4	6	95	100 x 34	72	20

**8003**
ŠROUBOVÁK BEZPEČNOSTNÍ TS
 SAFETY SCREWDRIVER TS

S LINE PROFÍ



NEW

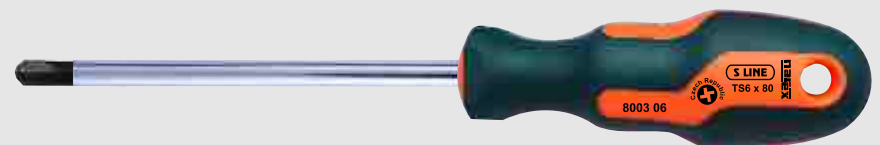

Code	Velikost Size	φd	mm	mm	g	
8003 06	TS 6	4,5	80	90 x 29	45	20
08	TS 8	6	95	100 x 34	72	20
10	TS 10	6	95	100 x 34	72	20

Šroubovák 8364 00 se speciálně tvarovanou pracovní částí, lze použít na šrouby PH 1-2-3, PZ 1-2-3.

Depending on the specified tip, screwdriver 8364 00 can be used for screws PH 1-2-3, PZ 1-2-3.

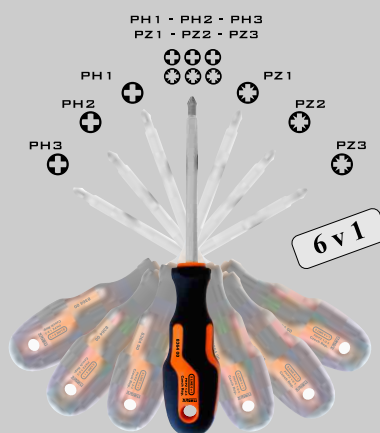
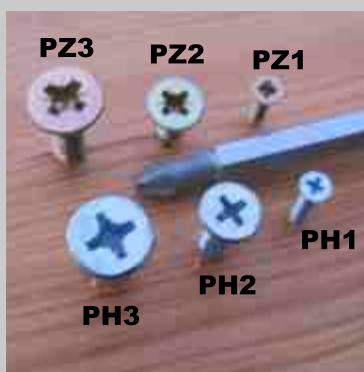

8003 ŠROUBOVÁK BEZPEČNOSTNÍ TW / 8003 SAFETY SCREWDRIVER TW



8002 ŠROUBOVÁK BEZPEČNOSTNÍ SP / 8002 SAFETY SCREWDRIVER SP



S LINE T PROFI

Dříky

- zušlechtná vysoce legovaná ocel
- povrch chromován
- pracovní část černěna
- některé typy dvouramenné, průchozí

Blades

- treated highly alloyed steel
- chrome plated surface
- working part black finish
- some types double-sided, through



Barevné kombinace dle typu šroubováku
Colour combinations according to type

Rukojetě

- ergonomické ve tvaru T umožňující vyvinout velký kroučicí moment
- tvrdé jádro z PP, měkčí část z TPE

Handles

- ergonomic T-shaped enabling high torque transfer
- hard PP core, soft TPE cover



Určeno pro práce v náročných podmínkách s vysokými kroučicími momenty
Suitable for work under difficult conditions with high torque

Šroubováky viz strana 26, jsou vybaveny otočnou částí pro snazší vedení šroubováku při práci
Screwdrivers from page 26 are equipped with revolving part for easier screwdriver guidance at work



Sady/Sets

stojánek
stand



závěsný stojánek
hanging stand

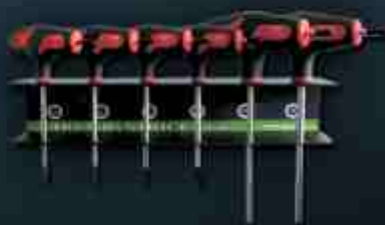

Podpora prodeje
Sales promotion

viz strana 90
see page 90



**8316****ŠROUBOVÁK MATICOVÝ
NUTDRIVER**

S LINE T PROFI

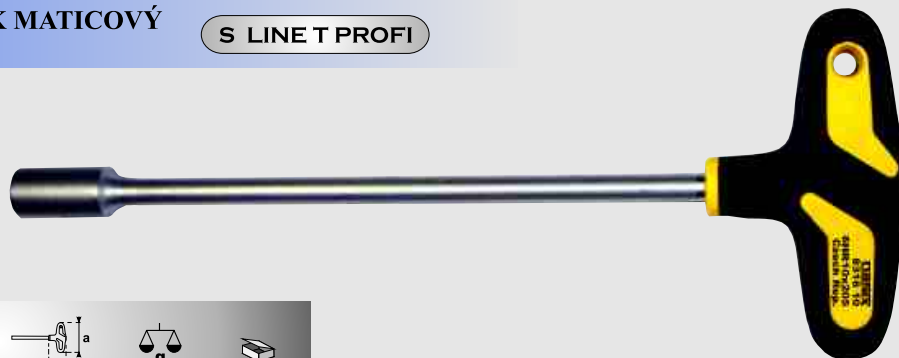

Code					
8316 08	SWM 8	205	100 x 57	151	20
09	SWM 9	205	100 x 57	152	20
10	SWM 10	205	100 x 57	154	20
11	SWM 11	205	100 x 57	160	20
12	SWM 12	205	100 x 57	162	20
13	SWM 13	205	100 x 57	166	20

**8315****ŠROUBOVÁK ŠESTIHRANNÝ
HEXAGON SCREWDRIVER**

S LINE T PROFI

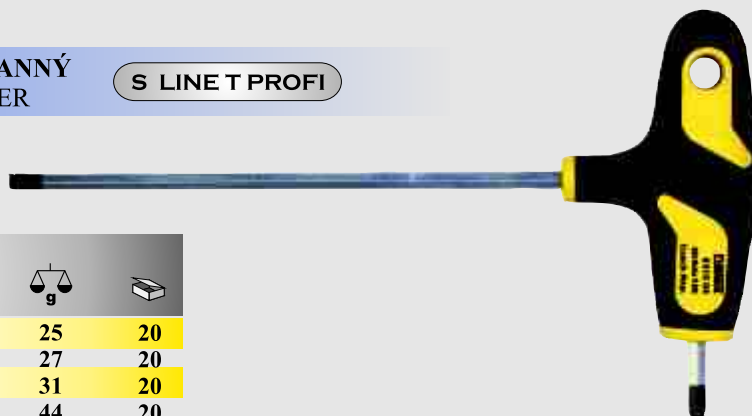

Code					
8315 01	SW 2	85	80 x 46	25	20
02	SW 2,5	85	80 x 46	27	20
03	SW 3	85	80 x 46	31	20
04	SW 4	135	80 x 46	44	20
05	SW 5	135	100 x 57	80	20
06	SW 6	180	100 x 57	109	20
08	SW 8	180	100 x 57	164	20
10	SW 10	185	100 x 57	234	20

**8314****ŠROUBOVÁK ŠESTIHRANNÝ s kulovou hlavou
HEXAGON SCREWDRIVER with ball end**

S LINE T PROFI

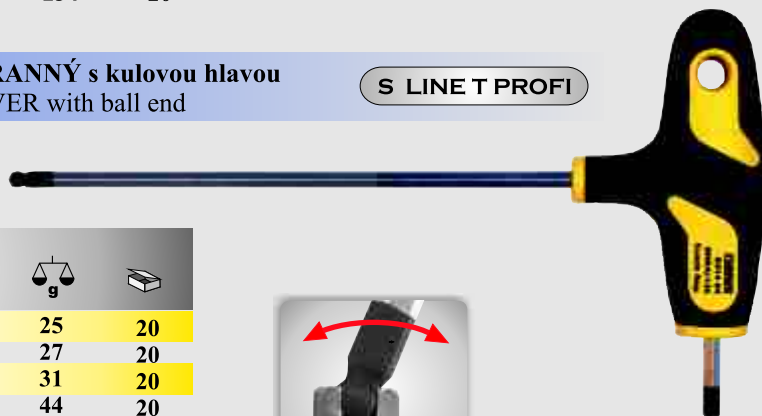

Code					
8314 01	SWK 2	85	80 x 46	25	20
02	SWK 2,5	85	80 x 46	27	20
03	SWK 3	85	80 x 46	31	20
04	SWK 4	135	80 x 46	44	20
05	SWK 5	135	100 x 57	79	20
06	SWK 6	180	100 x 57	108	20
08	SWK 8	180	100 x 57	163	20
10	SWK 10	185	100 x 57	232	20

**8089****ŠROUBOVÁK TX
SCREWDRIVER TX**

S LINE T PROFI

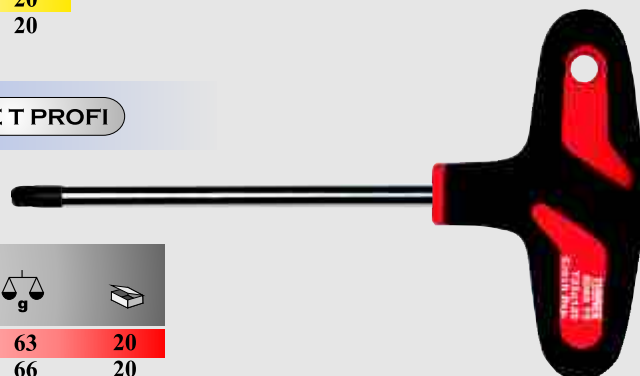

Code						
8089 70	TX 20	4	110	80 x 46	63	20
75	TX 25	4,5	120	80 x 46	66	20
77	TX 27	5	120	100 x 57	83	20
80	TX 30	6	120	100 x 57	83	20
90	TX 40	7	145	100 x 57	102	20
95	TX 45	8	145	100 x 57	145	20



8317

ŠROUBOVÁK TX
SCREWDRIVER TX

S LINE T PROFI

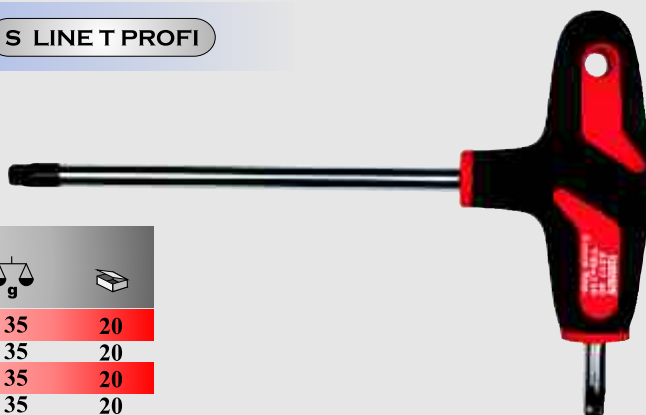

Code						
8317 09	TX 9	4	85	80 x 46	35	20
10	TX 10	4	85	80 x 46	35	20
15	TX 15	4	85	80 x 46	35	20
20	TX 20	4	85	80 x 46	35	20
25	TX 25	4,5	85	80 x 46	40	20
27	TX 27	5	130	100 x 57	76	20
30	TX 30	6	130	100 x 57	92	20
40	TX 40	7	130	100 x 57	161	20
45	TX 45	8	130	100 x 57	241	20



8322

ŠROUBOVÁK MAGNETICKÝ PRO NÁSTAVCE
MAGNETIC SCREWDRIVER FOR BITS

S LINE T PROFI

MAGNETIC



Code						
8322 10	1/4"	10	90	100 x 57	125	20



8802

ŠROUBOVÁK MAGNETICKÝ S NÁSTAVCI
MAGNETIC SCREWDRIVER WITH BITS

S LINE T PROFI

MAGNETIC

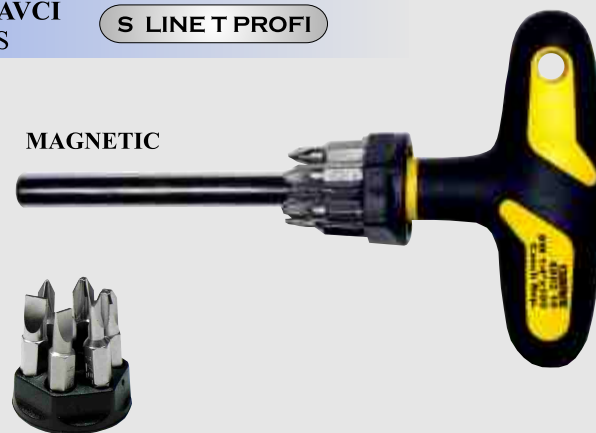

Code	8802 10			
Velikost Size	Obsah Content			
⊖ 4; 5; 6	8071 81; 82; 83			
⊕ PH 1; 2; 3	8072 81; 82; 83			
⊕ PZ 1; 2; 3	8073 81; 82; 83	205		5
⊕ TX 8; 15; 20	8074 48; 50; 51			
Zásobník pro nástavce 2x Bit holder 2x	8803 00			
Šroubovák Screwdriver	8322 10			



8703

KLÍČ S VNĚJŠÍM ČTYŘHRANEM
SQUARE DRIVE SOCKET DRIVER (MALE)

S LINE T PROFI



Code						
8703 10	1/4"	150	100 x 57	158	20	
20	3/8"	150	100 x 57	203	20	

**8704****KLÍČ S VNITŘNÍM ČTYŘHRANEM**
SQUARE DRIVE SOCKET DRIVER (FEMALE)**S LINE T PROFI**

Code					
8704 10	1/4"	150	100 x 57	135	20
20	3/8"	150	100 x 57	227	20

8512**SADA NÁSTRČNÝCH HLAVIC S KLÍČEM**
SET OF SOCKETS WITH SOCKETDRIVER**S LINE T PROFI****NEW**

Code	8512 00	
Obsah Content		
○ 5, 5,5, 6, 7, 8, 10, 12, 13, 14		421
○ 8703 10 Klíč s vnějším 4HR 1/4"		
Wrench with outer square 1/4"		

**SADY ŠROUBOVÁKŮ v závěsu**
SCREWDRIVER SETS in hanging stand**S LINE T PROFI**

Code 8510 01			Code 8511 01		
Velikost Size	Obsah Content		Velikost Size	Obsah Content	
○ TX 10	8317 10	680	○ SW 2	8315 01	690
○ TX 15	15		○ SW 2,5	02	
○ TX 20	20		○ SW 3	03	
○ TX 25	25		○ SW 4	04	
○ TX 27	27		○ SW 5	05	
○ TX 30	30	○ SW 6	06		



8510 01

SADY ŠROUBOVÁKŮ ve stojánku
SCREWDRIVER SETS in stand**S LINE T PROFI**

Code 8510 02			Code 8511 02		
Velikost Size	Obsah Content		Velikost Size	Obsah Content	
○ TX 10	8317 10	602	○ SW 2	8315 01	612
○ TX 15	15		○ SW 2,5	02	
○ TX 20	20		○ SW 3	03	
○ TX 25	25		○ SW 4	04	
○ TX 27	27		○ SW 5	05	
○ TX 30	30	○ SW 6	06		



8511 02

**8315** ŠROUBOVÁK ŠESTIHRANNÝ S OTOČNOU ČÁSTÍ
HEXAGON SCREWDRIVER WITH REVOLVING GRIP

S LINE T PROFÍ

NEW

Code					
8315 51	SW 2	85	80 x 46	27	20
52	SW 2,5	85	80 x 46	29	20
53	SW 3	85	80 x 46	33	20
54	SW 4	135	80 x 46	46	20
55	SW 5	135	100 x 57	83	20
56	SW 6	180	100 x 57	112	20
58	SW 8	180	100 x 57	167	20
60	SW 10	185	100 x 57	237	20



S LINE T PROFÍ

**8314** ŠROUBOVÁK ŠESTIHRANNÝ S KULOVOU HLAVOU A OTOČNOU ČÁSTÍ
HEXAGON SCREWDRIVER WITH BALL END AND REVOLVING GRIP

NEW

Code					
8314 51	SWK 2	85	80 x 46	27	20
52	SWK 2,5	85	80 x 46	29	20
53	SWK 3	85	80 x 46	33	20
54	SWK 4	135	80 x 46	46	20
55	SWK 5	135	100 x 57	82	20
56	SWK 6	180	100 x 57	111	20
58	SWK 8	180	100 x 57	166	20
60	SWK 10	185	100 x 57	235	20

**8309** ŠROUBOVÁK TX S OTOČNOU ČÁSTÍ
SCREWDRIVER TX WITH REVOLVING GRIP

S LINE T PROFÍ

NEW

Code						
8309 09	TX 9	4	85	80 x 46	37	20
10	TX 10	4	85	80 x 46	37	20
15	TX 15	4	85	80 x 46	37	20
20	TX 20	4	85	80 x 46	37	20
25	TX 25	4,5	85	80 x 46	42	20
27	TX 27	5	130	100 x 57	79	20
30	TX 30	6	130	100 x 57	95	20
40	TX 40	7	130	100 x 57	164	20
45	TX 45	8	130	100 x 57	245	20



Dlouhý dřík / Long blade

NEW

Code						
8309 60	TX 10	4	185	80 x 46	48	20
65	TX 15	4	185	80 x 46	48	20
70	TX 20	4	185	80 x 46	48	20
75	TX 25	4,5	185	80 x 46	55	20
77	TX 27	5	180	100 x 57	87	20
80	TX 30	6	180	100 x 57	107	20
90	TX 40	7	180	100 x 57	179	20
95	TX 45	8	180	100 x 57	266	20

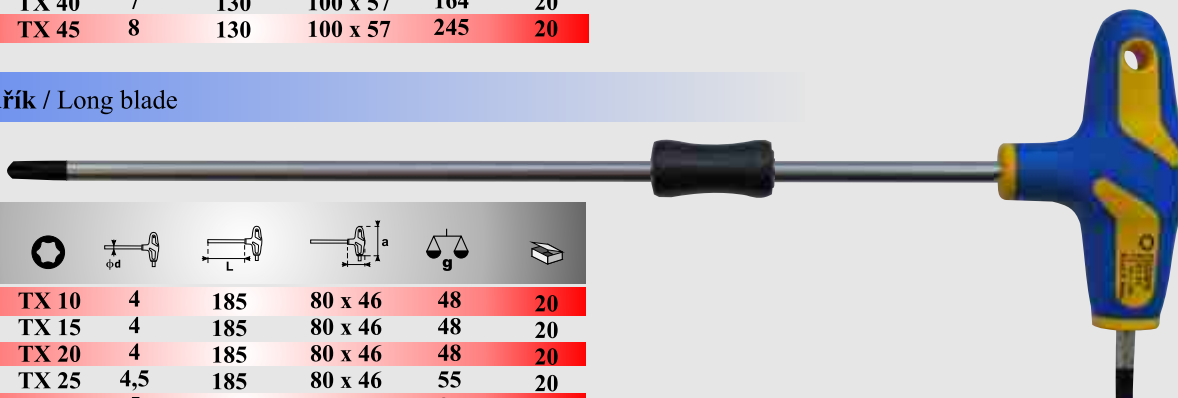



EASY FORCE PROFI

NEW

Dřívky

- zušlechťená vysoce legovaná Cr-V ocel
- zvýšená tvrdost
- výrazně vyšší pevnost
- povrch chromován
- pracovní část černěna

Blades

- treated highly alloyed Cr-V steel
- increased hardness
- significantly tighter fit
- chrome plated surface
- working part black finish



Barevné kombinace dle typu šroubováku
Colour combinations according to type

Rukojetě

- masivní se šestihranným průřezem a s šestihranným otvorem pro klíč
- tvrdé jádro z PP, měkčí část z TPE

Handles

- robust with hexagonal cross-section and hexagonal opening for wrench
- hard PP core, soft TPE cover

Pomocí přidavného klíče lze dosáhnout několikanásobného kroučicího momentu.
Multiple torque may be achieved with the use of the additional wrench.



Určeno pro náročnou práci vyžadující extrémně vysoký kroučicí moment
Suitable for difficult work that requires extremely high torque



Sady/Sets

plastový kufr
plastic case



narex

**8022****KLÍČ NÁSTRČNÝ ŠESTIHRANNÝ**
HEXAGONAL SOCKET WRENCH**EASY FORCE PROFI****NEW**

Code					
8022 00	6HR 1/4" HEX 1/4"	40	100 x 37	67	20

Určeno pouze pro šroubováky EASY FORCE PROFI.
Suited only for screwdrivers EASY FORCE PROFI.**8022****ŠROUBOVÁK PLOCHÝ**
SCREWDRIVER SLOTTED**EASY FORCE PROFI****NEW**

Code						
8022 01	1,2	6	125	105 x 33	103	20
02	1,2	6,5	150	105 x 33	112	20
03	1,2	7	150	105 x 33	130	20
04	1,2	8	175	117 x 36	178	20
05	1,6	10	200	117 x 36	190	20
06	2	12	250	117 x 36	230	20

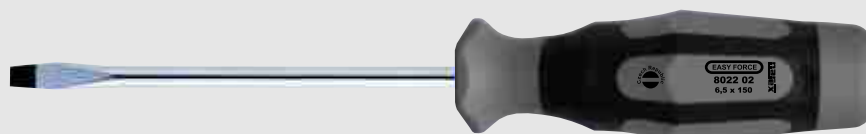
**8022****ŠROUBOVÁK PHILLIPS**
SCREWDRIVER PHILLIPS**EASY FORCE PROFI****NEW**

Code						
8022 12	PH 2	6	100	105 x 33	104	20
13	PH 3	8	150	117 x 36	166	20

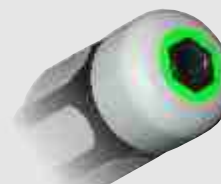
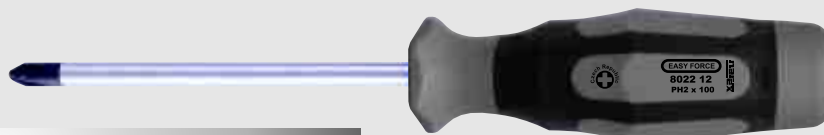
**8022****ŠROUBOVÁK POZIDRIV**
SCREWDRIVER POZIDRIV**EASY FORCE PROFI****NEW**

Code						
8022 22	PZ 2	6	100	105 x 33	104	20
23	PZ 3	8	150	117 x 36	166	20

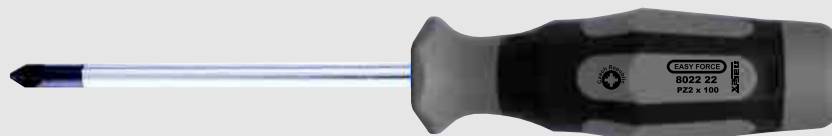



8022 ŠROUBOVÁK MATICOVÝ
NUTDRIVER

EASY FORCE PROFI

NEW

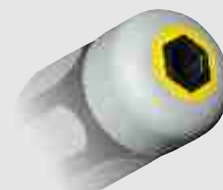
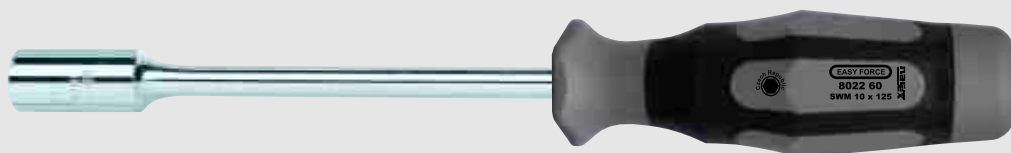

Code					
		mm	mm	g	
8022 58	SWM 8	125	105 x 33	126	20
59	SWM 9	125	105 x 33	134	20
60	SWM 10	125	105 x 33	146	20
61	SWM 11	125	117 x 36	158	20
62	SWM 12	125	117 x 36	166	20
63	SWM 13	125	117 x 36	172	20
64	SWM 14	125	117 x 36	178	20
65	SWM 15	125	117 x 36	184	20
66	SWM 16	125	117 x 36	190	20
67	SWM 17	125	117 x 36	196	20



8022 ŠROUBOVÁK TX
SCREWDRIVER TX

EASY FORCE PROFI

NEW

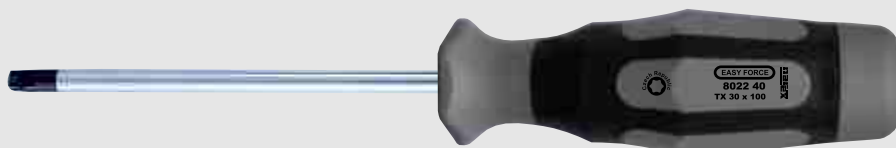

Code						
		φd	mm	mm	g	
8022 30	TX 30	6	115	105 x 33	108	20
40	TX 40	7	130	105 x 33	126	20
45	TX 45	8	130	117 x 36	158	20

8563 SADA ŠROUBOVÁKŮ v kufru
SCREWDRIVER SET in box

EASY FORCE PROFI

NEW

Code	8563 00	
Velikost Size	Obsah Content	
7,0 x 150	8022 03	
8,0 x 175	04	
PH2 x 100	8022 12	1233
PH3 x 150	13	
6HR/HEX	8022 00	





Kroučící moment / Torque
(Nm)

4 6 8 10 12 14 16 18 20 22 24 26 28

BĚŽNÝ ŠROUBOVÁK
ORDINARY SCREWDRIVER



EASY FORCE LINE PROFI



TWIN PLAST LINE PROFI



Barevné kombinace dle typu šroubováku

Colour combinations according to type

Dříky

- zušlechtěná vysoce legovaná ocel
- povrch chromován
- pracovní část černěna

Blades

- treated highly alloyed steel
- chrome plated surface
- working part black finish

Rukojetě

- ergonomické s tříhranným průřezem
- tvrdé jádro z PP, měkkí část z TPE
- tvar brání samovolnému pohybu při odložení

Handles

- ergonomic with three-square cross-section
- hard PP core, soft TPE cover
- the shape prevents it from rolling away



Určeno pro montáž a opravy v náročných podmínkách
Suitable for assembling and repairs under difficult conditions



Sady/Sets

kartonová krabice
carton box



plastový kufr
plastic case



Podpora prodeje
Sales promotion



viz strana 89
see page 89

narex®

**8004****ŠROUBOVÁK PLOCHÝ**
SCREWDRIVER SLOTTED

TWIN PLAST LINE PROFI



Code	a	b	ϕd	mm	mm	g	
8004 01	0,5	3	3	75	90 x 27	48	20
02	0,8	4	4	100	90 x 27	55	20
03	1	5,5	5	125	100 x 30	82	20
04	1,2	6,5	6	150	100 x 30	101	20
05	1,2	8	8	175	110 x 33	145	20
06	1,6	8	8	175	110 x 33	145	20
07	1,6	10	8	200	110 x 33	160	20

**8005****ŠROUBOVÁK PHILLIPS**
SCREWDRIVER PHILLIPS

TWIN PLAST LINE PROFI

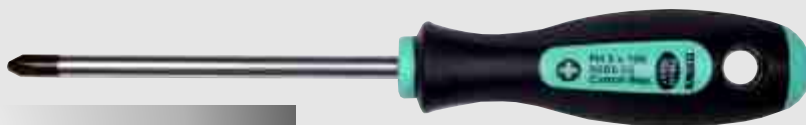

Code	+	ϕd	mm	mm	g	
8005 00	PH 0	3	60	90 x 27	32	20
01	PH 1	4,5	80	90 x 27	40	20
02	PH 2	6	100	100 x 30	68	20
03	PH 3	8	150	110 x 33	128	20

**8006****ŠROUBOVÁK POZIDRIV**
SCREWDRIVER POZIDRIV

TWIN PLAST LINE PROFI



Code	+	ϕd	mm	mm	g	
8006 00	PZ 0	3	60	90 x 27	32	20
01	PZ 1	4,5	80	90 x 27	40	20
02	PZ 2	6	100	100 x 30	68	20
03	PZ 3	8	150	110 x 33	128	20

**8081****ŠROUBOVÁK TX**
SCREWDRIVER TX

TWIN PLAST LINE PROFI

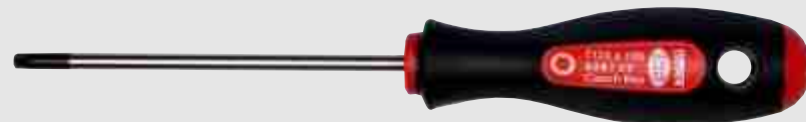

Code		ϕd	mm	mm	g	
8081 06	TX 6	3,5	60	90 x 27	38	20
08	TX 8	3,5	60	90 x 27	38	20
10	TX 10	4	80	90 x 27	40	20
15	TX 15	4	80	90 x 27	40	20
20	TX 20	4	100	90 x 27	56	20
25	TX 25	4,5	100	100 x 30	66	20
30	TX 30	6	115	100 x 30	66	20



8082

ŠROUBOVÁK TT s otvorem
SCREWDRIVER TT with hole

TWIN PLAST LINE PROFI



Code		ϕd				
			mm	mm	g	
8082 08	TT 8	3,5	60	90 x 27	32	20
09	TT 9	4	60	90 x 27	34	20
10	TT 10	4	80	90 x 27	38	20
15	TT 15	4	80	90 x 27	40	20
20	TT 20	4	100	100 x 30	42	20
25	TT 25	4,5	100	100 x 30	56	20
30	TT 30	6	115	100 x 30	70	20

SADY ŠROUBOVÁKŮ
SCREWDRIVER SETS

TWIN PLAST LINE PROFI

Code 8584 00

Velikost Size	Obsah Content	
		g
3,0 x 75	8004 01	548
4,0 x 100	02	
5,5 x 125	03	
8,0 x 175	05	
10,0 x 200	07	



Code 8587 00

Velikost Size	Obsah Content	
		g
3,0 x 75	8004 01	386
4,0 x 100	02	
6,5 x 150	04	
PH1 x 80	8005 01	02
PH2 x 100	02	



8584 00

Code 8647 01

Velikost Size	Obsah Content	
		g
3,0 x 75	8004 01	550
4,0 x 100	02	
6,5 x 150	04	
8,0 x 175	05	
PH1 x 80	8005 01	02
PH2 x 100	02	



8647 01

Code 8585 00

Velikost Size	Obsah Content	
		g
TX 6 x 60	8081 06	466
TX 8 x 60	08	
TX 10 x 80	10	
TX 15 x 80	15	
TX 20 x 100	20	
TX 25 x 100	25	
TX 30 x 115	30	



Code 8586 00

Velikost Size	Obsah Content	
		g
3,0 x 75	8004 01	546
5,5 x 125	03	
6,5 x 150	04	
PH1 x 80	8005 01	02
PH2 x 100	02	
PZ1 x 80	8006 01	02
PZ2 x 100	02	



8586 00